



WATER COOLERS

INSTALLATION/MAINTENANCE INSTRUCTIONS

BF1 Series Bottle Filler, Pushbutton Operated



TECHNICAL ASSISTANCE TOLL FREE TELEPHONE NUMBER:

1.800.591.9360

Technical Assistance Fax: 1.626.855.4894

NOTES TO INSTALLER:

1. Please leave this documentation with the owner of the fixture when finished.
2. Please read this entire booklet before beginning the installation.
3. Check your installation for compliance with plumbing, electrical and other applicable codes.

LIMITED WARRANTY - UNITED STATES & CANADA

Murdock warrants that its products are free from defects in material or workmanship under normal use and service for a period of one year from date of original shipment or for 18 months after the date of shipment from the factory, whichever comes first. Murdock's liability under this warranty shall be discharged solely by replacement or repair of defective material, provided Murdock is notified in writing within one year from date of shipment, F.O.B. Industry, California.

This warranty does not cover installation or labor charges and does not apply to materials, which have been damaged by other causes such as mishandling or improper care or abnormal use. The repair or replacement of the defective materials shall constitute the sole remedy of the Buyer and the sole remedy of Murdock under this warranty. Murdock shall not be liable under any circumstances for incidental, consequential or direct charges caused by defects in the materials, or any delay in the repair or replacement thereof. This warranty is in lieu of all other warranties expressed or implied. Product maintenance instructions are issued with each unit and disregard or non-compliance with these instructions will constitute an abnormal use condition and void the warranty. Stainless steel must be protected on job site during construction and must be properly maintained after the water has been introduced into the water cooler or drinking fountain, or Murdock's limited warranty is void.

LIMITED EXPORT WARRANTY - One year on parts only.

Murdock assumes no responsibility for use of void or suspended data. © Copyright Murdock, City of Industry, CA Member of Morris Group International. Please visit www.murdockmfg.com for most current specifications.

COMPLIES WITH
STANDARDS



Member of
MORRIS GROUP
INTERNATIONAL www.murdockmfg.com

MURDOCK
15125 Proctor Ave.
City of Industry, CA
91746 U.S.A.
Phone 800-591-9360
626-336-4561
Fax 626-855-4894

7109-708-001

Date: 07/15/16



WATER COOLERS

INSTALLATION/MAINTENANCE INSTRUCTIONS

PRIOR TO INSTALLATION

Important: Some options may slightly alter installation. To ensure proper installation review the manual thoroughly and verify rough-ins before beginning any work. File this manual with the owner or maintenance personnel upon completion of installation

- Fixture mounting requirements: Industry standard wall construction, adequate to support the fixture and (installer provided) wall anchors sufficient to secure the fixture.
- Fixture operates within water pressure range of 20 to 105 psig. Murdock will not warranty fixtures damaged when connected to supply lines with flow pressure lower than 20 psig or higher than 105 psig.
- Per UPC 609.10- *All building water supply systems in which quick acting valves are installed shall be provided with devices to absorb the hammer caused by high pressure resulting from the quick closing of the valve. These pressure-absorbing devices shall be approved mechanical devices. Water pressure-absorbing devices will be installed as close as possible to the quick closing valve.*
- Water supply inlet is 1/4" OD polyethylene tube.
- Completely flush supply of all foreign debris before connecting to fixture. Bottle filler is designed to provide trouble free drinking water unaffected by fixture connection tubing and fittings and not cause problems with taste, odor, color or sediment.

INSTALLATION INSTRUCTIONS:

1. Remove drinking cooler access panel and shut off water supply, then actuate valve to relieve pressure.

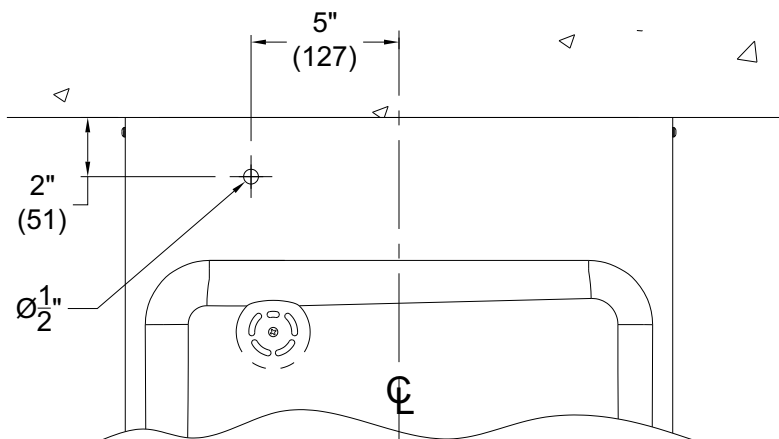

2. Drill 1/2" dia. hole thru drinking cooler deck (where shown above). Deburr hole and install grommet provided.

Drilling Notes:

- Wear approved safety glasses when drilling.
 - Prior to drilling stainless steel, adhere masking tape over drilling area to protect finish and provide marking surface.
 - Use a short, sharp high-speed drill bit and drill speed of 400-600 RPM; applying heavy pressure. Drill must cut at all times. DO NOT allow drill bit to ride, this will cause work hardening and will make it very difficult to drill or tap. Bibb washers, placed on drill shank will help to prevent marring the surface after the drill has broke through.
3. Mark vertical (plumb) center line on the wall, at the center of the drinking cooler deck.

Please visit www.murdockmfg.com
for most current specifications.

MURDOCK MFG. • 15125 Proctor Avenue • City of Industry, CA 91746 USA
Phone 800-453-7465 or 626-333-2543 • Fax 626-855-4860 • www.murdockmfg.com

Member of
MORRIS GROUP
INTERNATIONAL



WATER COOLERS

INSTALLATION/MAINTENANCE INSTRUCTIONS

INSTALLATION INSTRUCTIONS CONTINUED:

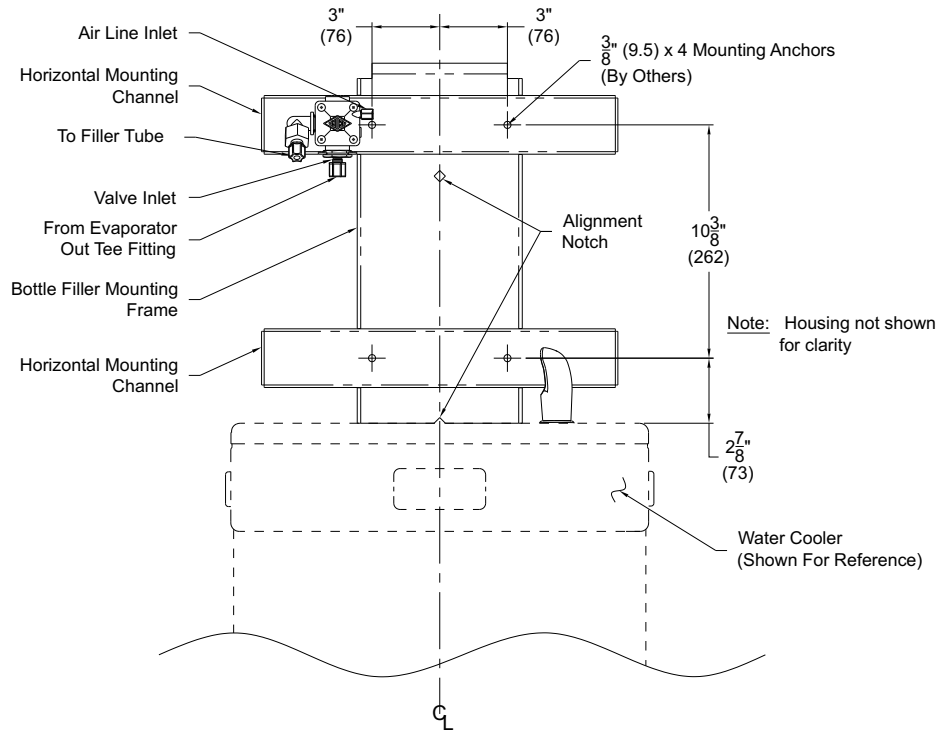

4. Carefully disassemble bottle filler. Remove the top, frame, horizontal mounting channels, and disconnect the PE tubing from the fill tube. (see page 5)
5. Use the frame as template, align notches in the frame with the vertical center line, and with the frame sitting on the deck
NOTE: COOLER SHOULD BE LEVEL.
6. Mark four mounting holes.
7. Install the four wall anchors (by others).
8. Align mounting frame and horizontal mounting channels to the anchors (as shown) and attach to wall with mounting fasteners (by others).
9. In drinking cooler access compartment, attach the "Y" strainer (provided) to existing 3/8" OD copper inlet tube and connect outlet of "Y" strainer to existing 1/4" OD evaporator inlet tube. (see page 4).
10. *In drinking cooler access compartment, remove the 1/4" push-in fitting from evaporator outlet and replace it with 1/4" push-in tee fitting. Reconnect the PE tube from the cartridge valve assembly to top of tee. (See page 4)
*See insert detail on page 4, for special installation instructions when installing on bi-level drinking fountains.
11. Remove the 18" piece of insulation from the 1/4" OD 30" PE tube. Pass the end of the 30" PE tube through the hole in the deck of the drinking cooler. Reinstall 18" piece of insulation on to the 30" PE tube, under deck. Connect the 30" PE tube to the side of the previously installed tee fitting, from step 10. (see page 4).
12. Reconnect 24" PE to fill tube.
13. To reassemble housing to mounting frame assembly, engage the left side of the housing behind the horizontal mounting channels, then stretch the housing over the right end of the horizontal mounting channels, make sure that the rubber trim on the housing is touching the water cooler deck. Secure the housing to the top channel, with #10-32 truss head screws provided.
14. reassemble and install top with #8-32 truss head screws provided.
15. Turn on the water supply stop, test unit and check for leaks, then reinstall access panel.

Please visit www.murdockmfg.com
for most current specifications.

MURDOCK MFG. • 15125 Proctor Avenue • City of Industry, CA 91746 USA
Phone 800-453-7465 or 626-333-2543 • Fax 626-855-4860 • www.murdockmfg.com

Member of
MORRIS GROUP
INTERNATIONAL



WATER COOLERS

INSTALLATION/MAINTENANCE INSTRUCTIONS

INSTALLATION INSTRUCTIONS CONTINUED:

WATER TUBING CONNECTIONS

NOTE: Insulation on all water tubes not shown (all PE water tubes are insulated).

Special Instructions
Bi-Level Drinking Fountains
ONLY INSERT DETAIL

When mounting bottle filler on unit with no compressor, only.

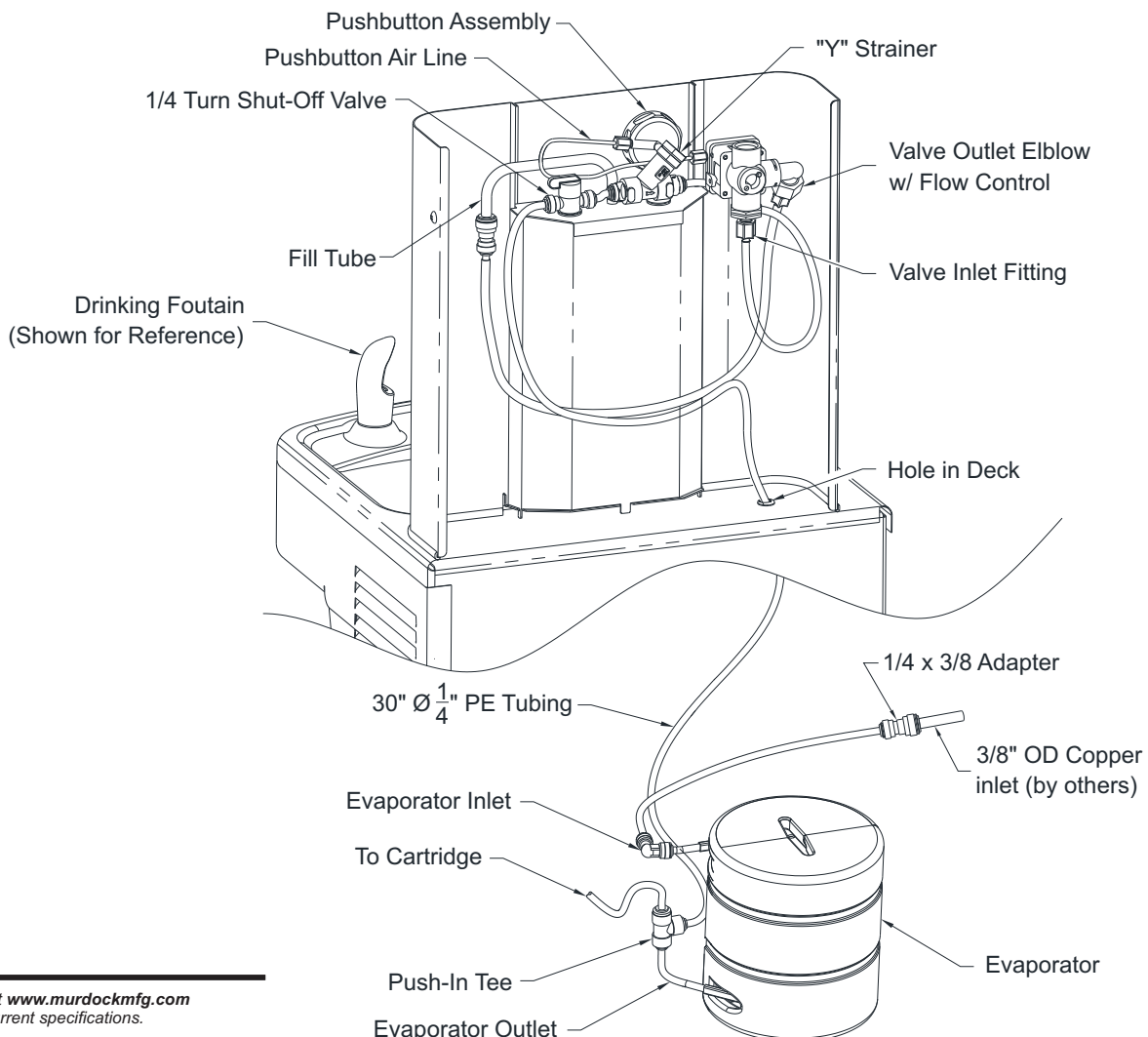

Please visit www.murdockmfg.com for most current specifications.



WATER COOLERS

INSTALLATION/MAINTENANCE INSTRUCTIONS

**RETRO-FIT INSTALL FOR EXISTING WATER COOLER FIXTURE:
PRESSURIZED SINGLE UNIT PIPE INSTALLATION (WITH -GF & -BF OPTIONS)**

ITEM	PART NUMBER	DESCRIPTION	QTY.
1	7012-055-000	FOAM INSULATION, PIPE, 3/8" ID x 1/4" THICK	5.5'
2	2169-000-000	TUBING, LLDPE, BLUE 1/4" OD	5'

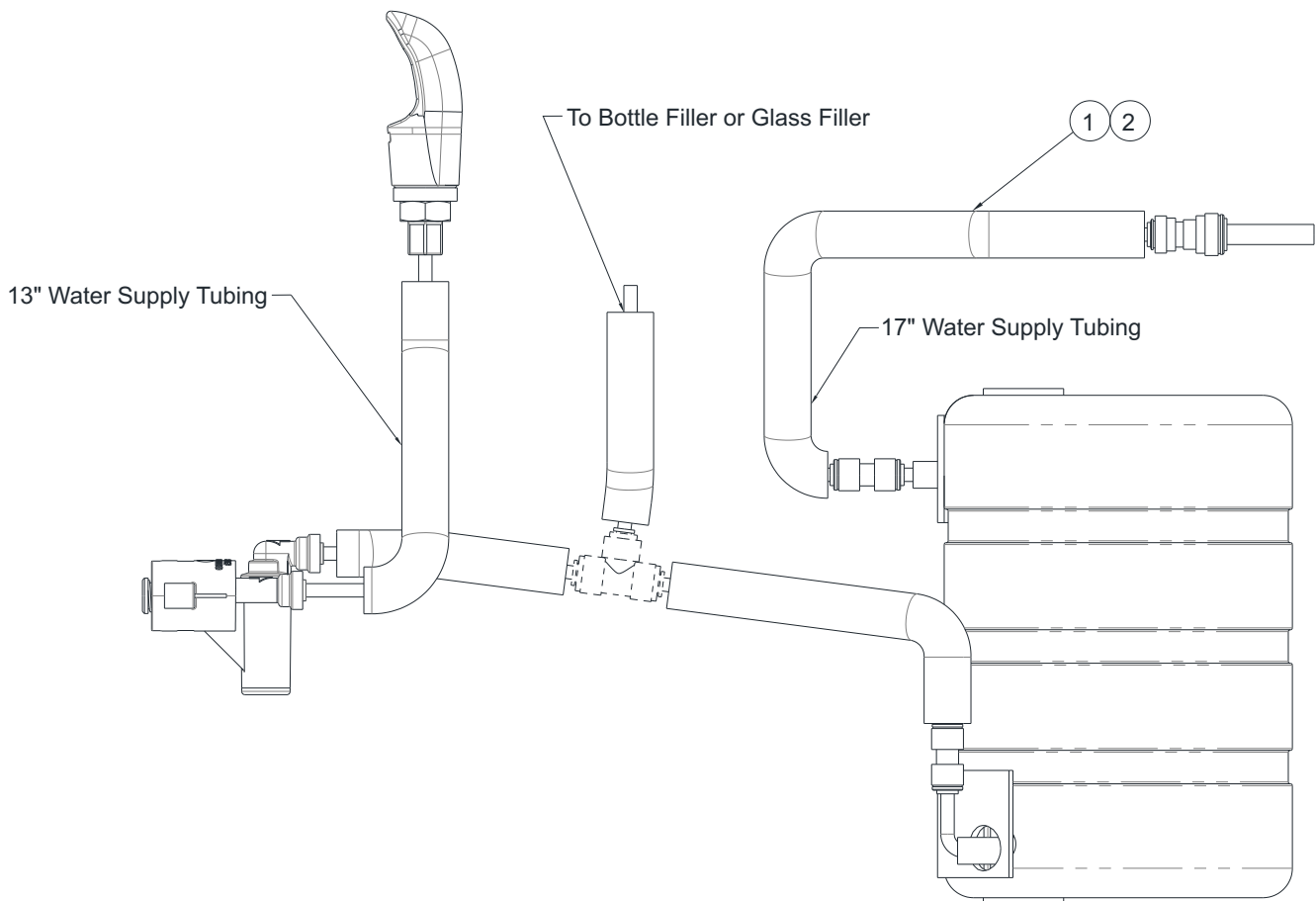

Please visit www.murdockmfg.com
for most current specifications.

MURDOCK MFG. • 15125 Proctor Avenue • City of Industry, CA 91746 USA
Phone 800-453-7465 or 626-333-2543 • Fax 626-855-4860 • www.murdockmfg.com

Member of
MORRIS GROUP
INTERNATIONAL



WATER COOLERS

INSTALLATION/MAINTENANCE INSTRUCTIONS

RETRO-FIT INSTALL FOR EXISTING WATER COOLER FIXTURE (NON-PRESSURIZED UNIT): RE-PIPING FROM NON-PRESSURIZED TO PRESSURIZED (FOR -GF & -BF ONLY)

To re-pipe a single non-pressurized unit to pressurized, you will have to move the water supply tubing around, with "NO" additional tubing needed. Before performing this task you **MUST SHUT OFF THE WATER SUPPLY**, and disconnect all supply connections.

STEP 1:

Starting with the supply line coming from the wall, connect to the inlet of the evaporator assembly.

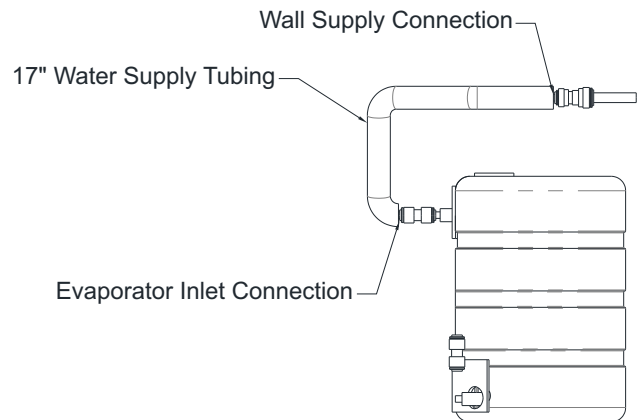

STEP 2:

From the outlet of the evaporator assembly, connect to the inlet of the cartridge assembly.

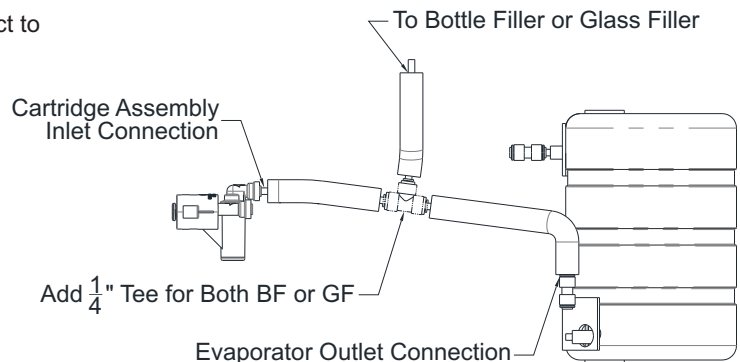

STEP 3:

From the outlet of the cartridge assembly, connect to the bubbler.

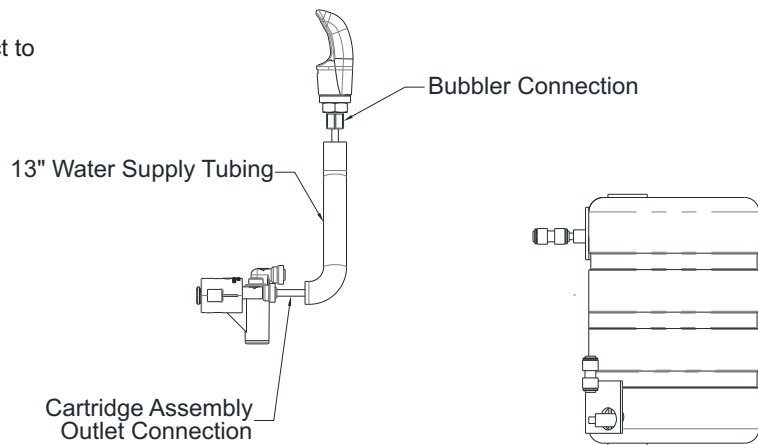

Please visit www.murdockmfg.com
for most current specifications.

MURDOCK MFG. • 15125 Proctor Avenue • City of Industry, CA 91746 USA
Phone 800-453-7465 or 626-333-2543 • Fax 626-855-4860 • www.murdockmfg.com

Member of
MORRIS GROUP
INTERNATIONAL



WATER COOLERS

INSTALLATION/MAINTENANCE INSTRUCTIONS

PUSH-IN FITTING INSTALLATION

NOTE: FITTINGS AND TUBE SHOULD BE KEPT CLEAN, BAGGED AND UNDAMAGED PRIOR TO INSTALLATION.

TO CUT TUBE:

Cut to fit length of 1/4" PE tubing and remove any burrs or sharp edges. Ensure that the outside diameter is free from score marks. Tube ends should be square.

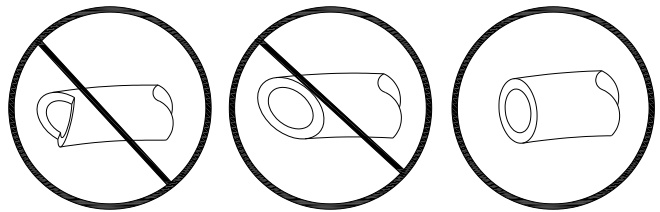

INSERTING THE TUBE:

1. Firmly and fully insert the tubing end into the push-in fitting up to the tube stop located approximately 1/2" deep.

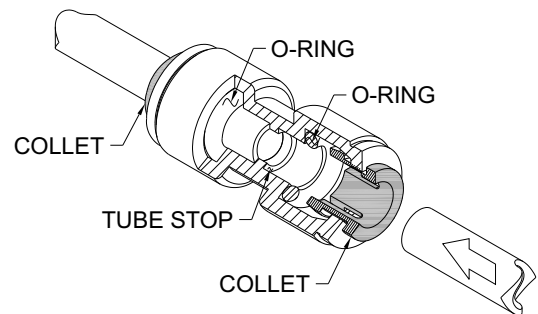

2. Pull on the fitted tubing to ensure it is secure. Tube should not come free from the fitting. Water test the connection assembly prior to leaving the site to ensure there are no leaks.

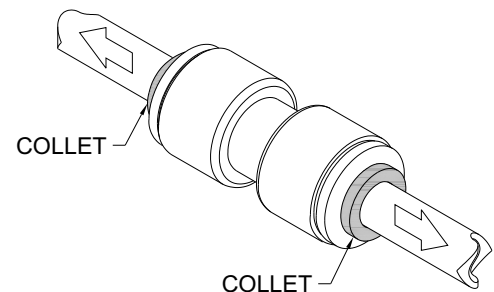

DISCONNECTING THE TUBE:

To disconnect the tube from the fitting ensure that the water line is depressurized. Push collet square towards the push-in fitting body and hold. While holding the collet in, pull on the PE tubing to remove from the push-in fitting.

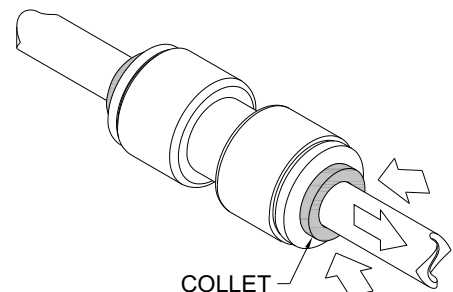

Please visit www.murdockmfg.com for most current specifications.



WATER COOLERS

INSTALLATION/MAINTENANCE INSTRUCTIONS

START UP:

1. Air within the bottle filler system or the structure supply piping will cause an irregular spout outlet stream until purged out by incoming water. Hold cup (or similar object) directly below filler spout is recommended when first activating bottle filler to prevent excessive splashing. Press and hold pushbutton until steady water stream is achieved.
2. Using the same method, hold cup (or similar object) directly over bubbler(s) and active bubblers until air is purged out and a steady stream is achieved.

OPERATING INSTRUCTIONS:

Hold container to be filled just below the filler tube in the center of the unit, then push pushbutton. When the container is almost filled, release the pushbutton.

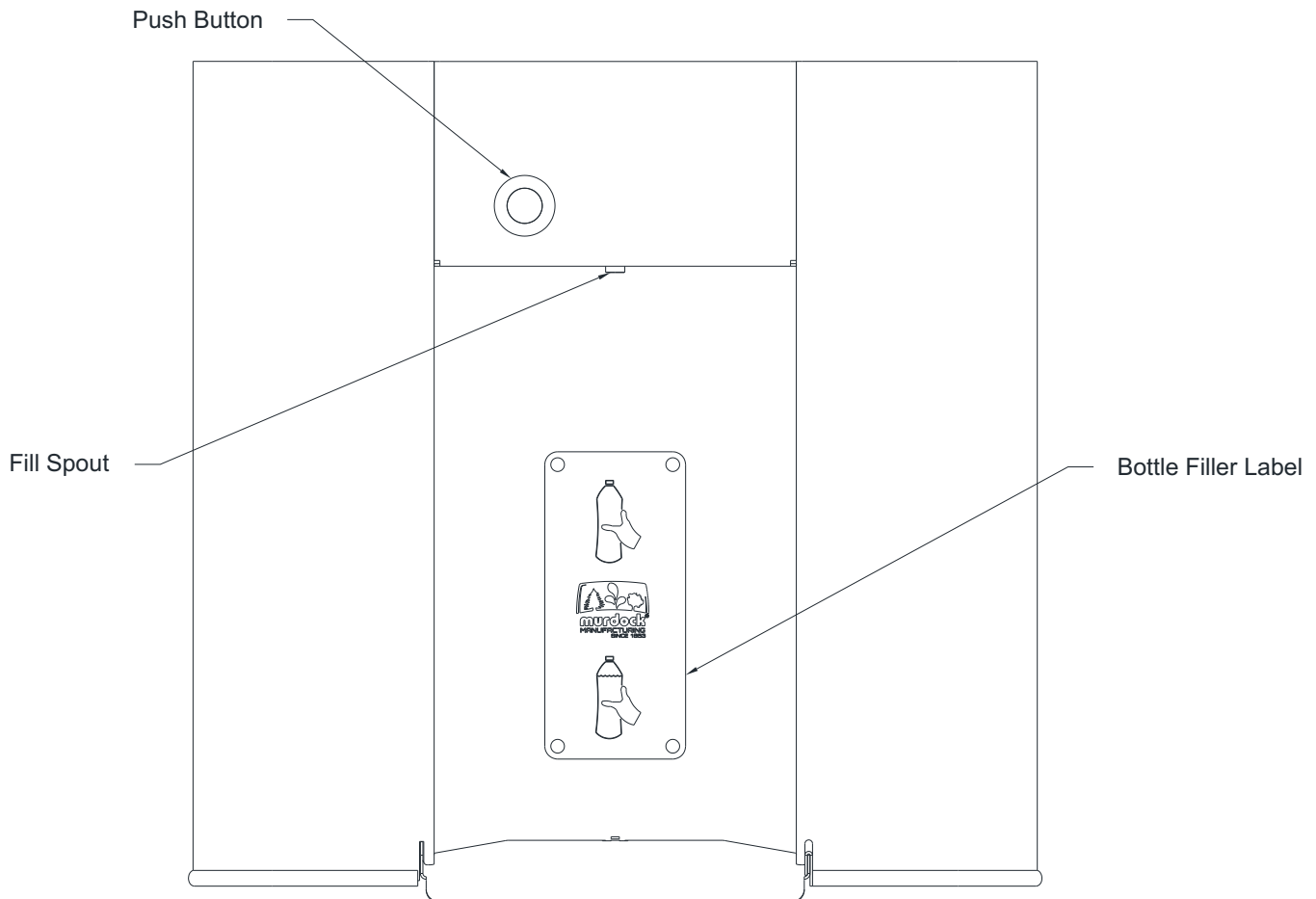

Please visit www.murdockmfg.com
for most current specifications.

MURDOCK MFG. • 15125 Proctor Avenue • City of Industry, CA 91746 USA
Phone 800-453-7465 or 626-333-2543 • Fax 626-855-4860 • www.murdockmfg.com

Member of  MORRIS GROUP
INTERNATIONAL



WATER COOLERS

INSTALLATION/MAINTENANCE INSTRUCTIONS

TROUBLE SHOOTING:

1. RESTRICTED OR NO WATER FLOW

- a. Ensure Water Supply service stop valve is fully open.
- b. Verify minimum 20 psig supply line flow pressure.
- c. Check for twist or kinks in spout tubing.
- d. Check the water inlet “Y” strainer. Sediment from the main supply can get trapped in the screen along with installation materials such as pipe dope and flux. The screen should be cleaned and checked on a regular basis and replace if needed.
- e. Flow control in solenoid valve outlet elbow clogged remove & clean.
- f. The water cooler may also develop a freezing condition in which the water will become frozen inside the evaporator coil. This indicates a refrigeration problem or thermostat failure in which case the water cooler needs to be checked by a qualified technician.

CLEANING & MAINTENANCE GUIDE:

1. To remove water spots or rust spots, stainless steel cleaner/polish on a cloth is recommended.
2. If there are stubborn spots or if you wish to treat a scratch, synthetic abrasive general purpose pads such as scotch brite are recommended.
3. Apply stainless steel cleaner/polish to the synthetic abrasive pads and carefully rub the panel with the grain.
4. DO NOT use harsh chemicals, abrasive or petroleum based cleaners. Use of these will void the Murdock warranty. DO NOT use abrasives on powder coated units.
5. Stainless steel should be kept clean at all times. If a coating of stainless steel cleaner/ polish is maintained, stainless steel surfaces will retain their new, clean, polished appearance indefinitely. Use clean mild soapy water for powder coated units.
6. Periodically remove access panel of cooler and clean out inline “Y” strainer.

Please visit www.murdockmfg.com
for most current specifications.

MURDOCK MFG. • 15125 Proctor Avenue • City of Industry, CA 91746 USA
Phone 800-453-7465 or 626-333-2543 • Fax 626-855-4860 • www.murdockmfg.com

Member of 
MORRIS GROUP
INTERNATIONAL



WATER COOLERS

INSTALLATION/MAINTENANCE INSTRUCTIONS

BOTTLE FILLER PARTS BREAKDOWN

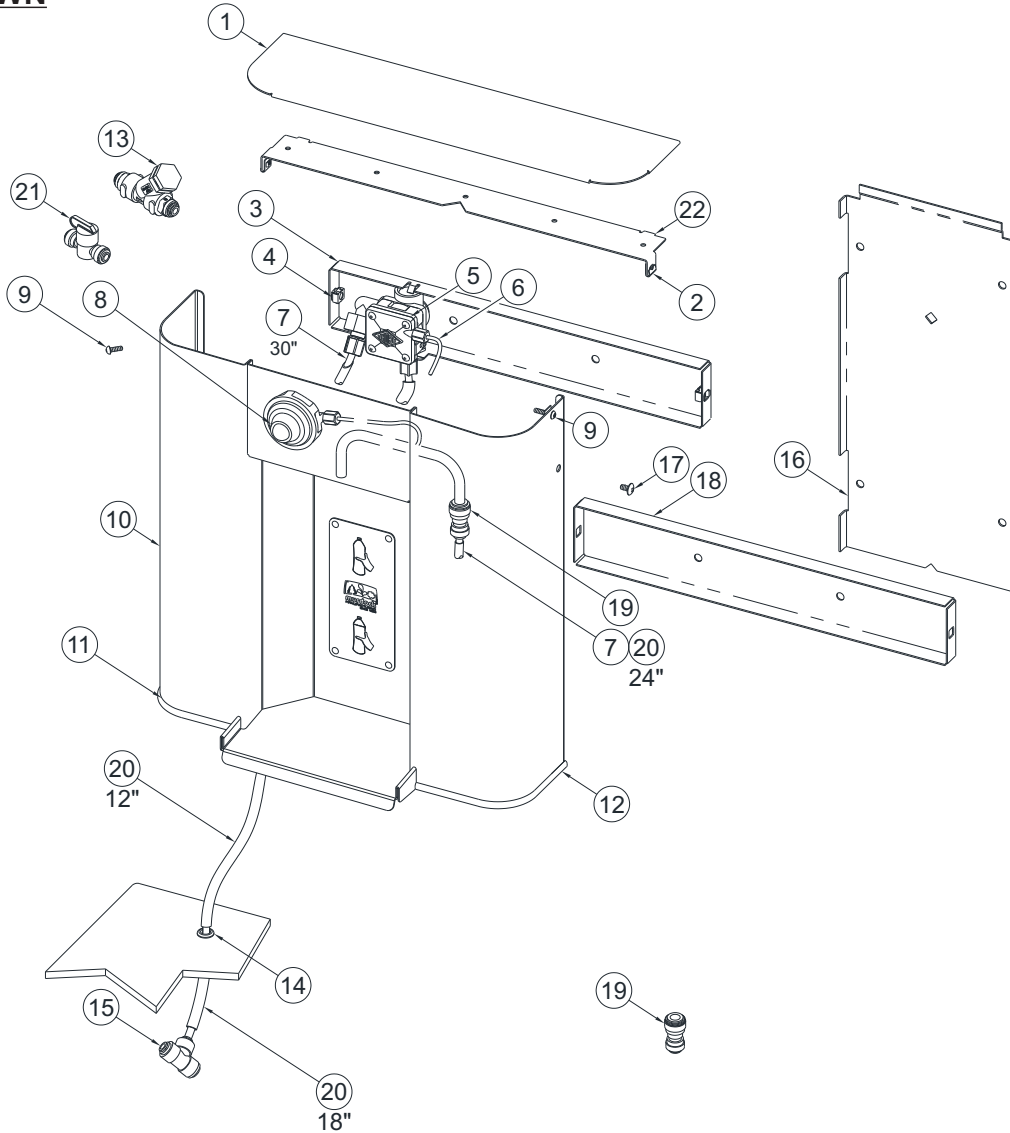

ITEM #	PART NUMBER	DESCRIPTION	ITEM #	PART NUMBER	DESCRIPTION
1	7014-004-199	Bottle Filler Top	12	7014-010-199	Bottle Filler Trim (Right)
2	7000-415-000	Self-Retaining J-Nut, SS	13	7013-210-001	1/4" "Y" Strainer, Bottle Filler
3	7014-007-001	Channel and Valve Assembly	14	7013-020-000	5/8" OD Grommet
4	0316-018-00	10-32 Stn Stl Nut Retainer	15	1895-710-000	1/4" Push-in Union Tee
5	7013-027-002	Air-Control Valve Assembly	16	7014-006-199	Bottle Filler Frame
6	2150-002-199	1/8" x 10" O.D. Clear PE Tubing	17	0112-021-000	#10-32 x 1/2" S/S Hex Btn Hd Screw
7	2169-000-000	1/4" OD LLDPE Tubing, Blue	18	7013-008-199	Bottle Filler Channel
8	2566-160-001	Pushbutton Assembly	19	1895-123-000	1/4" x 3/8" OD Push-In Tube Union
9	0279-002-000	#8-32 Socket Cap Btn Hd Screw	20	7012-055-000	Foam Insulation
10	7014-000-003	Bottle Filler Sub Assembly	21	7000-420-000	1/4 Turn Shut-Off Valve
11	7014-009-199	Bottle Filler Trim (Left)	22	7014-005-199	Bottle Filler Top Bracket

Please visit www.murdockmfg.com for most current specifications.

MURDOCK MFG. • 15125 Proctor Avenue • City of Industry, CA 91746 USA
 Phone 800-453-7465 or 626-333-2543 • Fax 626-855-4860 • www.murdockmfg.com

Member of
 MORRIS GROUP INTERNATIONAL